



Pallet Stackers

D06 – D10 | D08 M

Capacity 0.6 t – 1.0 t | Series 1162

PB

ION

Versatile manoeuvrable pallet handler

- Compact pedestrian double stacker for transporting goods over short-to-medium distances
- Versatile use in busy loading areas in supermarkets or in warehouses
- Lifting height up to 2 metres and load capacity up to 2000 kilograms
- Capable of handling two pallets at the same time
- Compact mono-mast version with optimum visibility, ideal for retail applications (D08 M)
- Innovative 5-point configuration with adjustable castor wheels for maximum stability

TECHNICAL DATA (according to VDI 2198)

			Model				
			D06	D08	D08 M	D10	
Characteristics	1.1	Manufacturer (abbreviation)	Linde MH	Linde MH	Linde MH	Linde MH	
	1.2	Manufacturer's type designation	D06	D08	D08 M	D10	
	1.2a	Series	1162-00	1162-00	1162-00	1162-00	
	1.3	Drive	Battery	Battery	Battery	Battery	
	1.4	Operation	Pedestrian	Pedestrian	Pedestrian	Pedestrian	
	1.5	Rated capacity/rated load	Q (t)	1.6/(0.6 + 1.0)	1.8/(0.8 + 1.0)	1.8/(0.8 + 1.0)	2.0/(1.0 + 1.0)
	1.6	Load centre distance	c (mm)	600	600	600	600
	1.8	Load distance, centre of drive axle to fork	x (mm)	873/936 ¹⁾²⁾	873/936 ¹⁾²⁾	859/922 ¹⁾²⁾	874/937 ¹⁾²⁾
	1.9	Wheelbase	y (mm)	1306/1369 ¹⁾²⁾³⁾	1306/1369 ¹⁾²⁾³⁾	1306/1369 ¹⁾²⁾³⁾	1425/1488 ¹⁾²⁾¹⁶⁾
Weight	2.1	Service weight	kg	638 ⁴⁾⁵⁾	664 ⁴⁾⁵⁾	621 ⁴⁾⁵⁾	830 ⁴⁾⁵⁾
	2.2	Axle loading, laden front/rear	kg	797/1441 ⁴⁾⁵⁾	858/1606 ⁴⁾⁵⁾	808/1613 ⁴⁾⁵⁾	986/1844 ⁴⁾⁵⁾
	2.3	Axle loading, unladen front/rear	kg	463/175 ⁴⁾⁵⁾	482/182 ⁴⁾⁵⁾	451/170 ⁴⁾⁵⁾	601/229 ⁴⁾⁵⁾
Tyres/chassis	3.1	Tyres: solid rubber, superelastic, pneumatic, polyurethane		Polyurethane	Polyurethane	Polyurethane	Polyurethane
	3.2	Tyre size, front		Ø 230 × 75	Ø 230 × 75	Ø 230 × 75	Ø 230 × 75
	3.3	Tyre size, rear		Ø 85 × 80 (Ø 85 × 60) ⁶⁾	Ø 85 × 80 (Ø 85 × 60) ⁶⁾	Ø 85 × 80 (Ø 85 × 60) ⁶⁾	Ø 85 × 80 (Ø 85 × 60) ⁶⁾
	3.4	Additional wheels (dimensions)		2x Ø 125 × 40	2x Ø 125 × 40	2x Ø 125 × 40	2x Ø 125 × 40
	3.5	Wheels, number front/rear (x = driven wheels)		1x + 2/2 (1x + 2/4) ³⁾	1x + 2/2 (1x + 2/4) ³⁾	1x + 2/2 (1x + 2/4) ³⁾	1x + 2/2 (1x + 2/4) ³⁾
	3.6	Tread, front	b10 (mm)	482 ²⁾	482 ²⁾	482 ²⁾	482 ²⁾
	3.7	Tread, rear	b11 (mm)	338/353/378 ²⁾⁷⁾	338/353/378 ²⁾⁷⁾	353/378 ²⁾⁷⁾	353/378 ²⁾⁷⁾
Dimensions	4.2	Mast height, lowered	h1 (mm)	1536	2060	1988	1474
	4.3	Free lift	h2 (mm)	989	1730	1460	150
	4.4	Lift	h3 (mm)	989 ²⁾	1730 ²⁾	1590 ²⁾	2024 ²⁾
	4.5	Mast height, extended	h4 (mm)	1661	2185	2220	2270
	4.6	Initial lift	h5 (mm)	125	125	125	125
	4.9	Height drawbar in operating position min./max.	h14 (mm)	810/1205 ²⁾	810/1205 ²⁾	810/1205 ²⁾	810/1205 ²⁾
	4.10	Height of wheel arms	h8 (mm)	60	60	60	60
	4.15	Height, lowered	h13 (mm)	86 ⁸⁾	86 ⁸⁾	86 ⁸⁾	86 ⁸⁾
	4.19	Overall length	l1 (mm)	1742 ²⁾³⁾	1742 ²⁾³⁾	1756 ²⁾	1860 ²⁾¹⁶⁾
	4.20	Length to fork face	l2 (mm)	592 ²⁾³⁾	592 ²⁾³⁾	606 ²⁾	710 ²⁾¹⁶⁾
	4.21	Overall width	b1/b2 (mm)	720 ²⁾	720 ²⁾	720 ²⁾	720 ²⁾
	4.22	Fork dimensions DIN ISO 2331	s / e / l (mm)	55/182/1150	55/182/1150	55/182/1150	55/182/1150
	4.24	Fork carriage width	b3 (mm)	514/529/554	514/529/554	650	710
	4.25	Fork spread	b5 (mm)	520/535/560	520/535/560	535/560	560
	4.31	Ground clearance, laden, below mast	m1 (mm)	20/145 ⁹⁾¹⁰⁾	20/145 ⁹⁾¹⁰⁾	20/145 ⁹⁾¹⁰⁾	20/145 ⁹⁾¹⁰⁾
4.32	Ground clearance, centre of wheelbase	m2 (mm)	20/145 ⁹⁾¹⁰⁾	20/145 ⁹⁾¹⁰⁾	20/145 ⁹⁾¹⁰⁾	20/145 ⁹⁾¹⁰⁾	
4.34.1	Aisle width for pallets 1000 × 1200 crossways	Ast (mm)	2325 ³⁾¹¹⁾¹²⁾	2325 ³⁾¹¹⁾¹²⁾	2328 ¹⁾¹²⁾	2444 ¹⁾¹²⁾¹⁶⁾	
4.34.2	Aisle width for pallets 800 × 1200 lengthways	Ast (mm)	2229 ³⁾¹¹⁾¹²⁾	2229 ³⁾¹¹⁾¹²⁾	2328 ¹⁾¹²⁾	2347 ¹⁾¹²⁾¹⁶⁾	
4.35	Turning radius	Wa (mm)	1512/1575 ¹³⁾	1512/1575 ¹³⁾	1512/1575 ¹⁾¹²⁾	1631/1694 ¹⁾¹⁶⁾	
Performance	5.1	Travel speed, laden/unladen	km/h	6/6 ¹³⁾	6/6 ¹³⁾	5/5 ¹³⁾	5/5 ¹³⁾
	5.1.1	Travel speed, laden/unladen, backwards	km/h	6/6 ¹³⁾	6/6 ¹³⁾	5/5 ¹³⁾	5/5 ¹³⁾
	5.2	Lifting speed, laden/unladen	m/s	0.094/0.152 ²⁾	0.094/0.152 ²⁾	0.129/0.197 ²⁾	0.12/0.183 ²⁾
	5.3	Lowering speed, laden/unladen	m/s	0.352/0.133 ²⁾	0.352/0.133 ²⁾	0.331/0.201 ²⁾	0.272/0.278 ²⁾
	5.8	Max. gradeability, laden/unladen	%	10.02/20.0	10.0/20.0	10.0/20.0	10.0/20.0
	5.9	Acceleration time, laden/unladen	s	7.0/6.6	7.3/7.0	7.0/6.5	7.3/6.6
	5.10	Service brake		Electric-engine	Electric-engine	Electric-engine	Electric-engine
Electric-engine	6.1	Drive motor rating S2 60 min	kW	1.3	1.3	1.3	1.3
	6.2	Lift motor rating at S3 15%	kW	1.2	1.2	1.2	1.2
	6.3	Battery according to DIN 43531/35/36 A, B, C, no		Li-ION compact	Li-ION compact	Li-ION compact	2 PzS-B
	6.4	Battery voltage/nominal capacity KS	(V)/(Ah) or kWh	24/62 (125) ¹⁴⁾	24/62 (125) ¹⁴⁾	24/62 (125) ¹⁴⁾	24/150
	6.5	Battery weight (±5%)	kg	14/23 ⁹⁾	14/23 ⁹⁾	14/23 ⁹⁾	134/154 ⁹⁾
	6.6	Energy consumption according to DIN EN 16796	kWh/h	0.51	0.59	0.64	0.68
	6.7	Turnover output according to VDI 2198	t/h	21.0	26.0	29.0	32.0
	6.8	Turnover efficiency according to VDI 2198	t/kWh	28	32	45	37
Additional data	10.7	Sound pressure level LpAZ (at the operator's seat)	dB(A)	58 ¹⁵⁾	58 ¹⁵⁾	61 ¹⁵⁾	58 ¹⁵⁾

1) Forks upraised/lowered

2) (±5 mm)

3) +50 mm = BS battery (2 PzS-B); +105 mm = 2 PzS battery

4) Figures with battery, see line 6.4/6.5.

5) (±10%)

6) Figures in parenthesis with tandem load wheels.

7) Depending on the forks spread; see 4.25

8) (-0/+5 mm)

9) min./max.

10) (±2 mm)

11) Including a 200 mm (min.) operating aisle clearance.

12) With creep speed = tiller in vertical position

13) (±5%)

14) (Option)

15) (±2.5)

16) +0 mm = BS battery (2 PzS-B); +5 mm = 2 PzS battery

D06

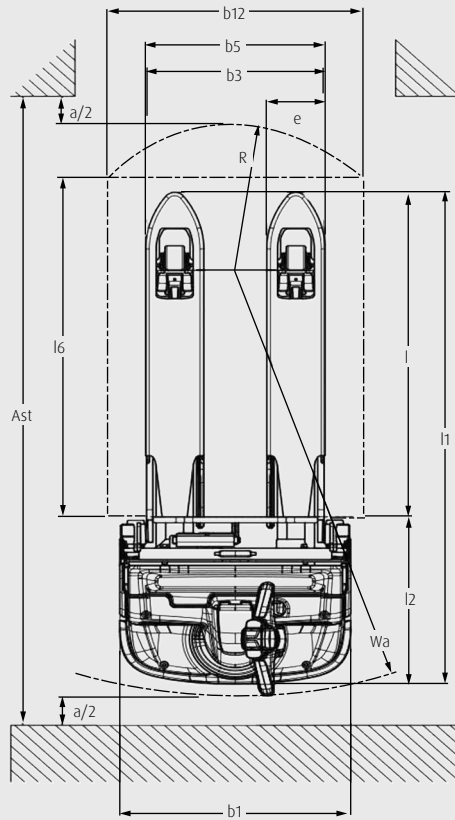
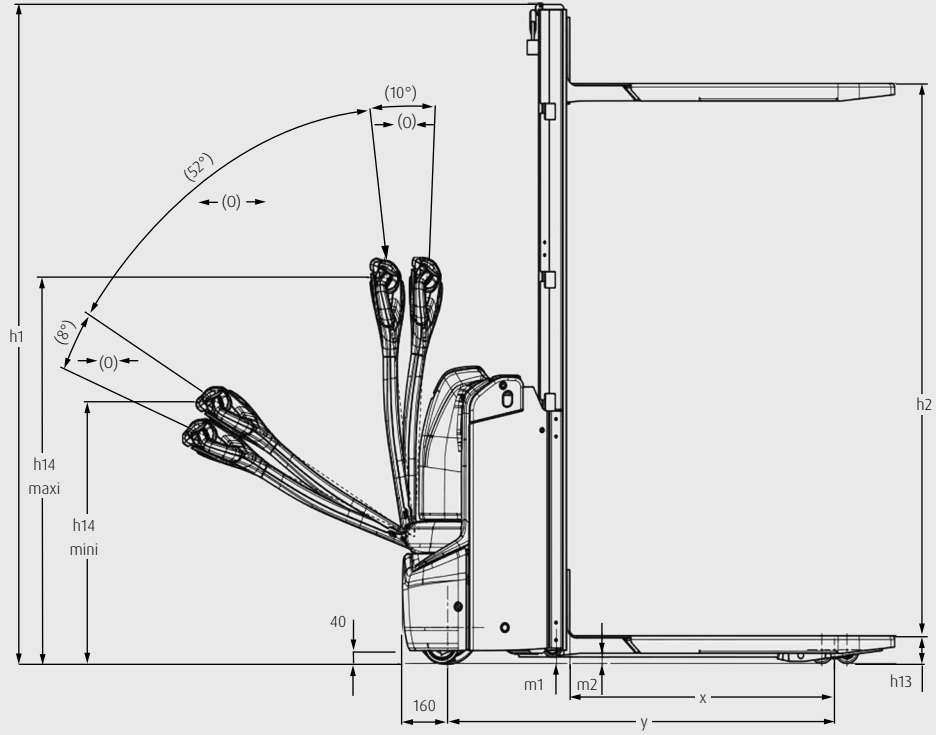

D08 M

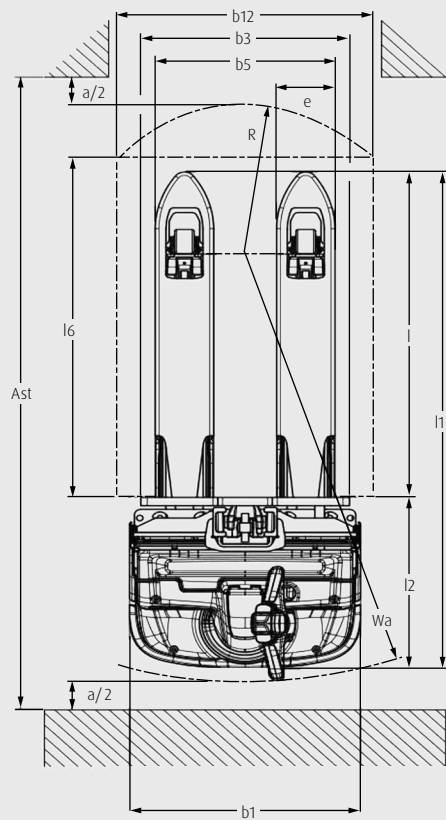
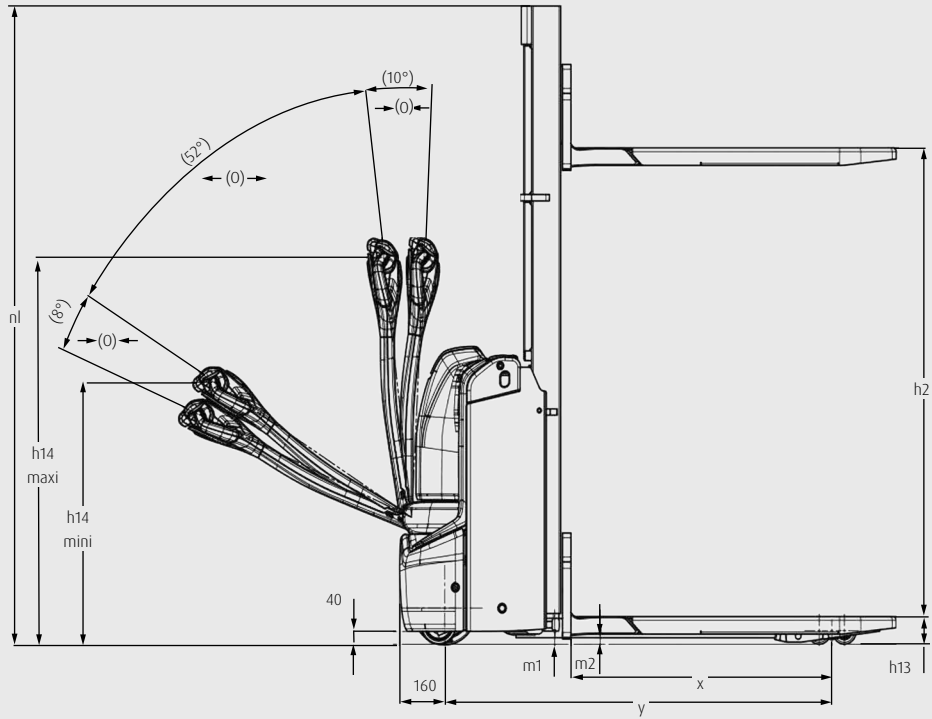

D10

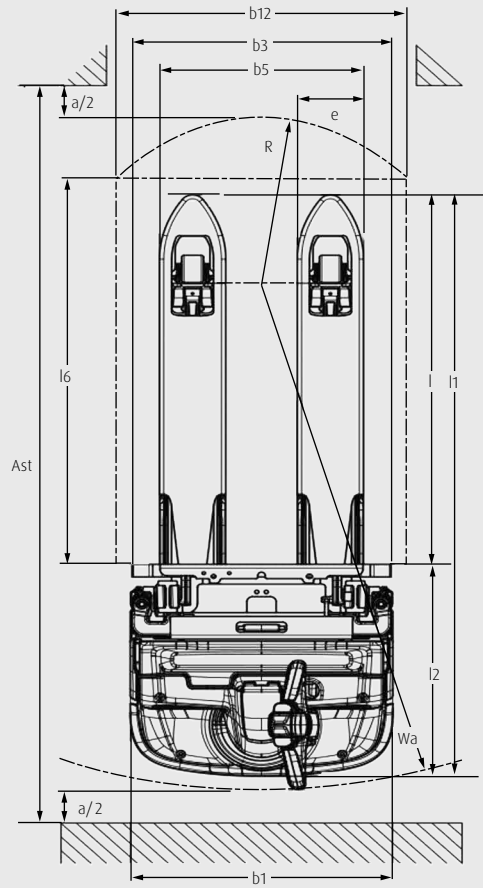
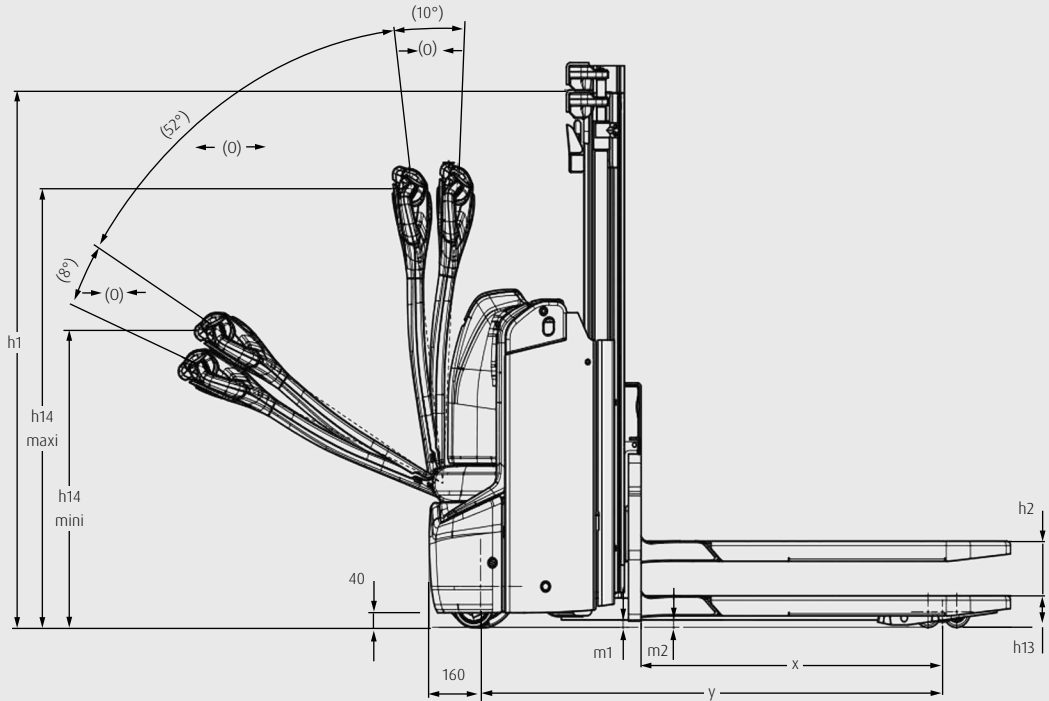

MAST TABLES

STANDARD MAST (in mm)

Lift	h3: 1574		h3: 1724		h3: 2024	
Height measurements	h1: 1240	h2: 150	h1: 1315	h2: 150	h1: 1465	h2: 150
Manufacturer's type designation						
D06	○		○		○	
D08	○		○		○	
D10	○		○		○	

SIMPLEX MAST (in mm)

Lift	h3: 989		h3: 1730		h3: 958		h3: 1590	
Height measurements	h1: 1532	h2: 150	h1: 2056	h2: 150	h1: 1635	h2: 150	h1: 1989	h2: 150
Manufacturer's type designation								
D06	○		○		—		—	
D08	○		○		—		—	
D08 M*	—		—		○		○	

○ Optional equipment — Not available

h1: Mast height, lowered

h2: Free lift

h3: Lift

* Mono mast

STANDARD AND OPTIONAL EQUIPMENT

Manufacturer's type designation/equipment		D06	D08	D08 M	D10
Safety	Active foot bumper – foot protection system	○	○	○	○
	Long tiller and low chassis skirt	●	●	●	●
	Automatic speed reduction when cornering	●	●	●	●
	Easily accessible emergency stop button	●	●	●	●
	Buzzer – for operation in low noise environments	●	●	●	●
	Horn – for operation in noisy environments	○	○	○	○
	Key switch	●	●	●	●
	Log in PIN code	○	○	○	○
Service	Linde BlueSpot – visual warning of truck presence	○	○	○	○
	CAN bus technology	●	●	●	●
Digitisation	Data transmission online	○	○	○	○
	Data transmission WiFi	○	○	○	○
	Linde connect.ac pre-shift check – allows operator to report truck condition before use	○	○	○	○
	Linde connect.dt crash detection – allows electronic impact damage monitoring	○	○	○	○
Operation/load handling	Automatic lifting – up and down	○	○	○	○
	Additional side buttons to raise and lower forks	○	○	–	○
	Lift end stop sensor	●	●	●	●
	Soft landing of forks	○	○	○	○
	Proportional speed control – traction speed dependent on tiller angle	○	○	○	○
	Creep speed control – allows operation at reduced speed when tiller is vertical	●	●	●	●
	OptiLift fully proportional lifting function	●	●	●	●
Environment	Coldstore protection-35°C (in/out)	○	○	○	○
Workplace	Multi-function display – hour meter, maintenance due, battery discharge and internal fault code indication	●	●	●	●
	Ergonomic tiller head with easy access to all controls	●	●	●	●
	Load backrest h = 800 mm, or h = 900 mm, from top of forks	○	○	○	○
	Accessory support	○	○	○	○
	Support for clipboard and scanner	○	○	○	○
	Metal battery cover	○	○	○	○
Mast	Standard mast	○	○	–	○
	Simplex mast	○	○	–	–
	Mono mast simplex	–	–	○	–
	Mast protection, polycarbonate	●	●	○	●
	Mast protection, wire mesh	○	○	–	○
	Mast protection, metallic	–	–	●	–
Attachment/forks	Width over forks: 520 mm, 535 mm, 540 mm, 560 mm	○	○	○	○
	Fork length: 1150 mm, 1190 mm, with overhang 55 mm	○	○	○	○
Axles and tyres	Drive wheel: standard duty	●	●	●	●
	Drive wheel: heavy duty, high grip	○	○	○	○
	Single load wheel, polyurethane	●	●	●	●
	Tandem load wheels, polyurethane	○	○	○	○
	Tandem load wheels, polyurethane greasable	○	○	○	○
	Auto-adjustable castor wheels	●	●	●	●
Drive and brake system	Maintenance-free AC motor	●	●	●	●
	Electromagnetic braking system	●	●	●	●
	Battery compartment for vertical change	○	○	●	–
	Battery compartment, 2 PzS-B, vertical change	●	●	–	●
	Battery compartment, 2 PzS, lateral or vertical change	○	○	–	○
Energy	Li-ION batteries – different battery capacities	○	○	○	○
	Lead acid batteries	○	○	○	○
	On-board charger 35 A or 70 A for lead-acid and Li-ION batteries	○	○	○	○
	Li-ION front plug for fast, easy opportunity charging	○	○	○	–
	Li-ION plug, laterally or vertically mounted for convenient opportunity charging	○	○	–	○
	External stand-alone chargers	○	○	○	○

● Standard equipment ○ Optional equipment – Not available

CHARACTERISTICS



Long, low-mounted tiller arm

Safety

- Long, low-mounted tiller arm maintains a safe distance between operator and truck
- Low chassis skirt and active foot bumper (option) protects operator's feet
- Hill start feature prevents rollback on inclines
- Wrap-around tiller head design protects operator's hands
- Mono mast (D08 M) provides unobstructed visibility of load and surroundings



Ergonomic tiller head

Ergonomics

- Control of all functions via the ergonomic tiller head
- Truck can be easily controlled by one hand
- All controls can be operated by gloved hands
- Effortless manoeuvring in tight spaces
- Storage compartments for work equipment available

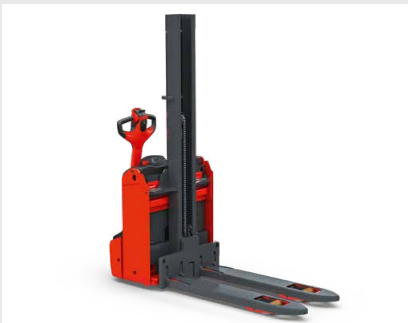

D08 M with mono mast

Handling

- OptiLift proportional lifting system ensures precise load handling
- Compact design for optimum manoeuvrability in confined spaces
- Creep speed function enables precise, safe operation even with tiller vertical
- Traction speeds up to 6 km/h for fast, efficient load transfers
- Fast opportunity charging with optional li-ion battery and on-board charger
- Mono mast facilitates order picking and shelf replenishment (D08 M)

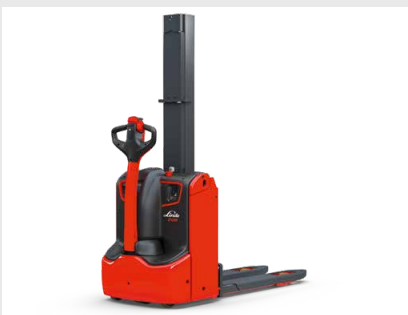

Robust truck design

Service

- Robust truck design increases reliability
- Easy access to all main components for time-saving service
- Steel-reinforced tiller arm for reliable operation in tough applications
- CAN bus structure for efficient fault diagnosis
- Long service intervals ensure low maintenance costs

Subject to modification in the interest of progress. Illustrations and technical specifications could include options and are not binding for actual constructions. All dimensions subject to usual tolerances.

Presented by:

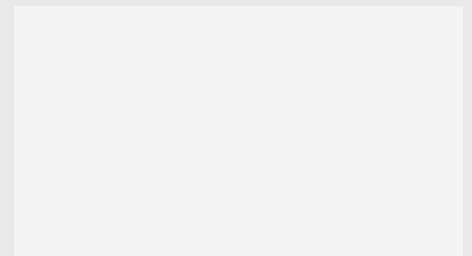

Linde Material Handling GmbH

Carl-von-Linde-Platz | 63743 Aschaffenburg | Germany
Phone + 49 6021 99 0 | Fax + 49 6021 99 1570
www.linde-mh.com | info@linde-mh.com

DS_D06-D10_D08M_1162_en_A_0724